CATALOG

ABB drives for HVACR

ACH180, 0.5 to 30 HP (0.37 to 22 kW)



—

Essential and reliable climate control in a compact footprint. ACH180 drives for HVACR.

Table of contents

04	ACH180 drives software with essential HVACR features
06–07	Simplify your HVACR application with reliable and cost-effective performance
08	Typical HVACR applications
09	Standard interface for ACH180 HVACR drives
10	ABB AC drives comply with the EU Ecodesign requirements
11	How to select a drive
12	Technical data
13	Ratings, types and voltages
14	Dimensions
15	Cooling and fuses
16	EMC – electromagnetic compatibility
17	Control panel options and mounting kits
18	Drivetune mobile app for managing drives via an intuitive interface
19–20	Commissioning, programming, customization and monitoring tools
21	ACH180 drives are compatible with the wide ABB product offering
23–24	Our service expertise, your advantage
25	ABB Drives Life Cycle Management

ACH180 drives software with essential HVACR features



One drive to control different types of motor. The ACH180 supports induction, permanent magnet and ferrite assisted synchronous reluctance motors, for increased energy savings in HVACR.

HVACR specific software. Multiple application features are built into the ACH180 including fireman's override, flying starts, critical speed control, load curve based filter monitoring, leakage or dry run protection, etc. The support of most common building automation protocols like Modbus and BACnet comes as standard as well.

"Mini PLC" included in the drive. By using intuitive and visualized Adaptive Programming, which offers numerous logical or mathematical function blocks, the user can build their own logic to scale up and customize the drive to specific HVACR application's requirements. The PC tool Drive Composer Entry, which is used to edit the Adaptive Programming, is also free.

Energy optimization function can automatically adjust the motor flux to its most efficient level: this helps reduce motor current and thus reduce power consumption and noise in quadratic torque applications like fans and pumps.

Protective and process limit functions for both the motor and the machine. These include overload, overheat, overcurrent, overvoltage, phase loss, phase-ground protections, and limit of speed, torque, or time. It also features drive-based safe-torque-off to protect personnel who are doing maintenance activities.

Load profile feature collects drive values, such as current and stores them in a log. This enables you to analyze and optimize the application with the help of historical data load.



Simplify your HVACR applications with reliable and cost-effective performance

The ACH180 drive is equipped with built-in HVACR application specific features that simplify ordering delivery, and reduce commissioning costs. It's a perfect fit for OEMs in a single, compact and ready-to-use package.

User-friendly interface

The user-friendly display and simple menu icons, makes it easy to set up the drive without diving into lengthy manuals. You can also enhance the interface with a customizable control panel that uses text and graphics. This menu-driven system optimizes the setup and operation for OEMs and most HVACR applications.



Advanced software tools for easy configuration, startup and maintenance

Drive Composer PC tool can be connected to the drive via an RJ-45 interface for easy startup, configuration, monitoring and process tuning. Adaptive programming allows the customization of the drive software replacing the need for a PLC.

Built-in EMC filter

High-frequency noise can directly affect sensitive electronic equipment and high-speed communication fieldbuses. The ACH180 drive is equipped with a built-in EMC filter to reduce high-frequency emissions.

Simple and flexible installation

The compact size of the ACH180 allows for side-by-side mounting and optimized cabinet space. The installation process is quick and easy thanks to spring cage terminals and wires that remain in place.



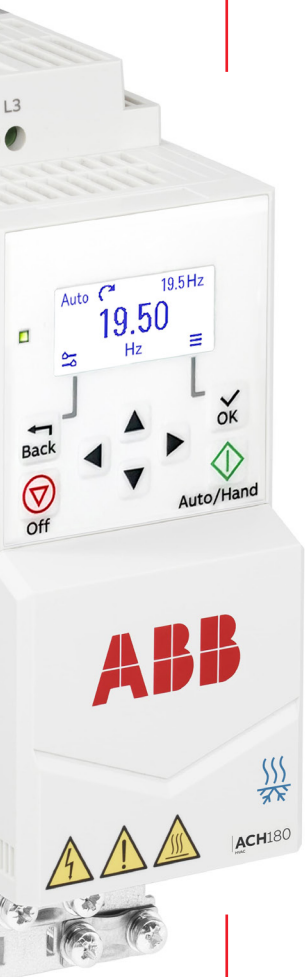

Essential HVACR functionality

Essential HVACR features are built-in: fireman's override, soft pump, fan or compressor start and stop, resonance control, bearing health monitoring, pump dry run protection hand-off auto controls, four start interlocks, motor flying start and motor pre-heat,



Motor control options

ACH180 can be integrated with several AC motor types, including induction, permanent magnet (PM) and EC Titanium™ motors. The ability to use high efficiency motor technologies can reduce your energy costs even more.

Reliable design

Design features like coated circuit boards, minimized airflow through the electronics, earth fault protection, and its design for a 40 °C (up to a 60 °C with derate) ambient temperature makes the ACH180 a safe choice for customers expecting high reliability. This is further enhanced by a full load test that is carried out on every single drive during production.



Built-in communication

The standard Modbus RTU, N2 and BTL-certified BACnet MS/TP interface enables effortless connectivity with a building automation network.



Remote connectivity

The optional Bluetooth® capability together with ABB's Drivetune smartphone app allows for remote drive commissioning, providing access to the same menus available on the drive's control panel in a familiar look and feel as other ACH products.











Safe torque off

Safe torque off (SIL 3, PL e) is a standard built-in feature in ACH180 drives.

Refrigerant compatible

The ACH180 is compatible with modern refrigeration systems using A2L and A3 Refrigerants that result in a safe solution for refrigerants use with a GWP (Global Warming Potential) less than 700.

Application	Customer benefits
01 Air handlers 	<ul style="list-style-type: none"> • Substantial energy savings at partial loads • Filter monitoring with user-defined load curves • Drive-based control capabilities and fieldbuses to enhance external controller tasks and eliminate gateways • Safe torque off (SIL 3) function for personnel safety when conducting maintenance on mechanical parts • Minimized downtime with robust and reliable design • Fireman's override mode for increased occupant safety
02 Fans 	<ul style="list-style-type: none"> • Substantial energy savings at partial loads • Resonance control
03 Fan arrays 	<ul style="list-style-type: none"> • Cost effective installation • Substantial energy savings at partial loads • Drive switching frequency adjustment for lower fan noise
04 Burners 	<ul style="list-style-type: none"> • Burner control ensures the hot water for heating or domestic use has the required temperature
05 Cooling towers 	<ul style="list-style-type: none"> • Optimized entering condenser water temperature for higher efficiency • Increased fan lifetime thanks to soft starts and stops
06 Pumps 	<ul style="list-style-type: none"> • Dry pump run protection • Soft start and stop to avoid water hammer
07 Compressors 	<ul style="list-style-type: none"> • Critical speed control • Easy start with 150% of the rated starting torque for 1 minute every 10 minutes with no need for oversized drive • Substantial energy savings at partial loads
08 Humidifiers 	<ul style="list-style-type: none"> • Precise humidity control • Optimized water usage

Standard interface for ACH180 HVACR drives

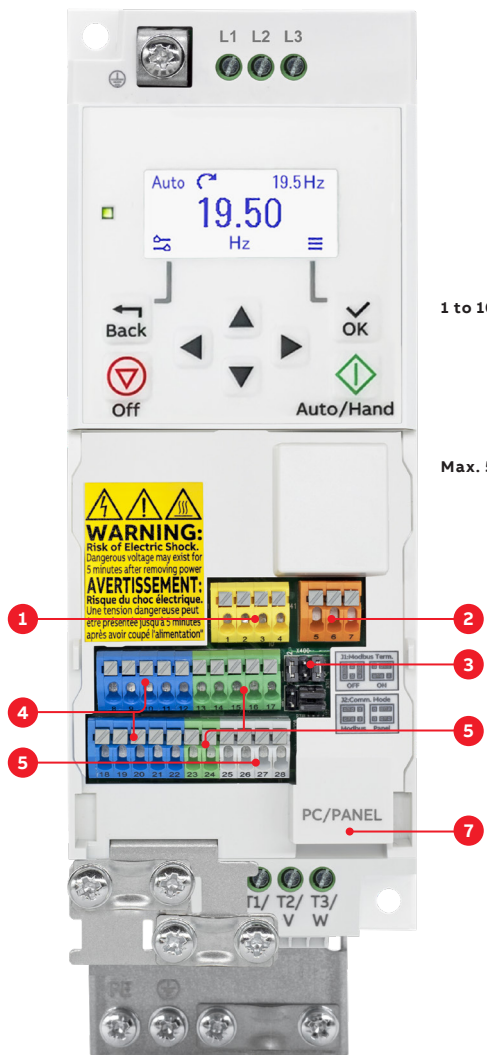

1. Safe torque off (STO)
2. Relay output
3. Modbus termination
4. Digital inputs and outputs
5. Analog inputs and outputs
6. EIA-485 Modbus RTU, BACnet MS/TP
7. Panel connector (external panel or adapter for PC connection)

Default I/O connections of standard variant

Terminals	Descriptions
Digital inputs and outputs	
21 24 V	Aux. +24 V DC, max 200 mA
22 DGND	Aux. voltage output common
8 DI1	Stop (0)/Start (1)
9 DI2	Not configured
10 DI3	Constant speed selection
11 DI4	Start interlock 1 (1=allow start)
12 DCOM	Digital input common
18 DO	Not energized
19 DO COM	Digital output common
20 DO SRC	Digital output auxiliary voltage
Analog inputs and outputs	
14 AI1/DI5	Speed reference (0...10 V)
13 AGND	Analog input circuit common
15 AI2	Not used
16 AGND	Analog input circuit common
17 AO	Output frequency (0...20 mA)
23 10 V	Reference voltage +10 V DC
24 SCREEN	Signal cable shield (screen)
Safe torque off (STO) *	
1 S+	Safe torque off function.
2 SGND	Connected at the factory. Drive starts only when both circuits are closed.
3 S 1	
4 S 2	
Relay output	
5 NC	
6 COM	Damper control
7 NO	
EIA-485 (Modbus RTU, BACnet MS/TP, etc.)	
25 B+	
26 A-	
27 AGND	Embedded fieldbus (EIA-485).
28 SHIELD	
Termination	
PC/PANEL connection	
PC/PANEL(RJ45)	Use standard Cat 5e or better Ethernet cable with male RJ45 connector to connect external control panel. Or use the BCBL-01 (USB to EIA-485) cable to connect the drive with PC directly. Note: This connection is not a network port, DO NOT connect it to Ethernet.



ABB AC drives comply with the EU Ecodesign requirements

The Ecodesign regulation (EU) 2019/1781 is the legislative framework, that sets minimum energy efficiency requirements for low voltage induction motors and variable speed drives. AC drives and power drive systems are classified according to their power losses. From July 2021, the minimum requirement for non-regenerative AC drives in EU is IE2.

ABB's AC drives (micro and machinery, general purpose, industrial and industry-specific drives) comply with the strictest requirements of the standard for energy efficiency and are classified as IE2.

Energy efficiency classes for a Complete Drive Module (CDM)

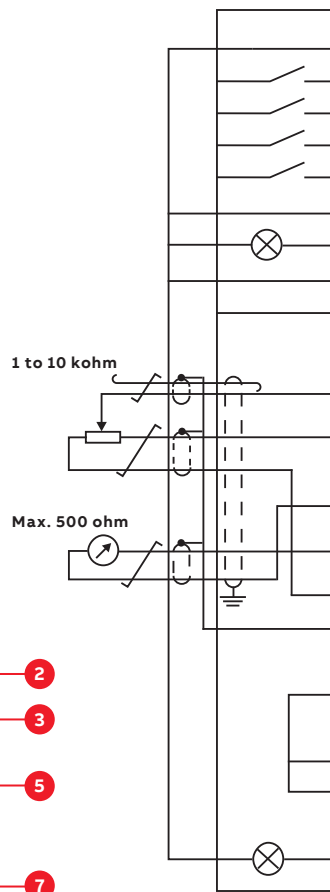
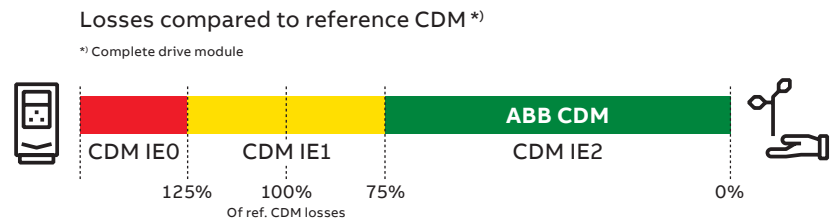

Markings on the ABB LV AC drives

Unique identifier QR code to Ecodesign information



IE class and % loss of rated apparent power 50 Hz, 400 V

IE2 (90;100) 2,3 %

Unique QR codes are located on the rating plate and/or the front side of the drive.

ABB provides tool to make efficiency calculation easy



- Calculates absolute and relative losses and efficiency data at standard and user-defined operating points according to EU regulation 2019/1781 for complete drive module (CDM), LV motors with VSD supply, and power drive system (PDS)
- Losses and efficiency data at operating points in graphical and table format
- Printable efficiency report with possibility to customize title and additional details
- Report can be converted to PDF or CSV format and shared via email

The regulation was implemented in two steps:

Step 1: July 1, 2021

- Power range: from 0.12 to 1000 kW
- 3-phase LV AC drives with diode rectifier
- Drive manufacturers must declare power losses in percentage of the rated apparent output power at 8 different operating points as well as standby losses. The international IE level is given at the nominal point. Drives fulfilling the requirements will be CE marked.

Excluded from the regulation:

- All drives without CE marking
- Following low voltage AC drives: regenerative drives, low-harmonic drives (THD < 10%), multiple AC-output drives and single-phase drives.
- Medium voltage drives, DC drives and traction drives
- Drive cabinets with already conformity assessed modules

Step 2: July 1, 2023

No changes for AC drives

Technical data

Mains connection	
Voltage and power range	1-phase, 200 to 240 V, +10%/-15% 0.5 to 3 HP (0.37 to 3 kW) 3-phase, 200 to 240 V, +10%/-15% 0.5 to 15 HP (0.37 to 11 kW) 3-phase, 380 to 480 V, +10%/-15% 0.75 to 30HP (0.55 to 22 kW)
Supply network type	TN, TT, IT ACH180-04N-xxxx-4 does not support corner-grounded delta network
Frequency	from 47 to 63 Hz
Power factor	cosφ = 0.98
Efficiency (at nominal power)	98%
Efficiency class (IEC 61800-9-2)	IE2
Motor connection	
Voltage	0 to U_N , 3-phase
Frequency	0 to 599 Hz
Motor control	Scalar control Sensorless vector control
Switching frequency	1.5 to 12 kHz, default 4 kHz
Braking power connection	
Brake chopper	Only on frames R2 to R4
Brake resistor	Only on frames R2 to R4
DC connection	Only on frames R2 to R4
Control and connectivity	
Analog input	2 x AI 0(4)-20mA or 0-10V - Configured by Parameter AI1 can be used as DI5
Analog output	1 x AO 0(4)-20mA or 0-10V configured by parameter
Digital input	4 x DI PNP or NPN configured by parameter
Digital output	1 x DO Transistor output, 60mA
Relay output	1 x RO NO+NC, 230 V, 2 A
Communication	1 x RJ45 for external control panel/PC tool Terminals for EIA-485 Modbus RTU/ BACnet MS/TP

Functional safety	
Built-in safety features (for ACH180-04S-xxxx-x)	Safe torque off (STO) acc. to EN/IEC61800-5-2: IEC61508 ed2: SIL 3, IEC 61511: SIL 3, IEC 62061: SIL CL 3, EN ISO 13849-1: PL e
Environmental limits	
Ambient temperature	
Operation	-10 to 50 °C (up to 60 °C with derate)
Transportation and storage	-40 to +70 °C
Cooling method	Air-cooled, dry clean air
Altitude	0 to 2,000 m (see allowed power systems in HW manual) derating above 1,000 m
Relative humidity	5 to 95%, no condensation allowed
Degree of protection	IP20 as standard
Contamination levels	No conductive dust allowed
Storage	IEC 60721-3-1, Class 1C2 (chemical gases) Class 1S2 (solid particles)
Transportation	IEC 60721-3-2, Class 2C2 (chemical gases) Class 2S2 (solid particles)
Operation	IEC 60721-3-3, Class 3C2 (chemical gases) Class 3S2 (solid particles)
Product compliance	
	CE Low Voltage Directive 2014/35/EU, EN 61800-5-1: 2007 Machinery Directive 2006/42/EC, EN 61800-5-2: 2007 EMC Directive 2014/30/EU, EN 61800-3: 2004 + A1: 2012 RoHS directive 2011/65/EU and delegated directive (EU) 2015/863 Ecodesign (EU) 2019/1781 China RoHS II GB/T 26572 UL, cUL TÜV Nord (safety functions) UKCA Quality assurance system ISO 9001 and Environmental system ISO 14001 Waste electrical and electronic equipment directive (WEEE) 2002/96/EC
EMC according to EN 61800-3:2004 + A1:2012	
	ACH180-04S/N-xxxx-1: Class C2 as standard
	ACH180-04S/N-xxxx-2: Class C3 as standard
	ACH180-04S/N-xxxx-4: Class C3 as standard



Ratings, types and voltages

1-phase, $U_N = 230\text{ V}$ (range 200 to 240 V). The power ratings are valid at nominal voltage 230 V (0.5 to 3HP).

Drive type	Frame size	Heavy-duty use		Light-duty use	
		I_{Hd} (A)	P_{HD} (hp)	I_{Ld} (A)	P_{Ld} (hp)
ACH180-04S-02A4-1	R0	1.8	.33	2.4	.5
ACH180-04S-03A7-1	R0	2.4	.5	3.5	.75
ACH180-04S-04A8-1	R0	3.7	.75	4.6	1.0
ACH180-04S-06A9-1	R1	4.5	1.0	6.6	1.5
ACH180-04S-07A8-1	R1	6.6	1.5	7.5	2.0
ACH180-04S-09A8-1	R1	7.5	2.0	9.8	3.0
ACH180-04S-12A2-1	R2	9.8	3.0	11.6	3.0

3-phase, $U_N = 230\text{ V}$ (range 200 to 240 V). The power ratings are valid at nominal voltage 230 V (0.5 to 15 HP).

Drive type	Frame size	Heavy-duty use		Light-duty use	
		I_{Hd} (A)	P_N (hp)	I_{Ld} (A)	P_{Ld} (hp)
ACH180-04S-02A4-2	R0	1.8	.33	2.4	.5
ACH180-04S-03A7-2	R0	2.4	.5	3.5	.75
ACH180-04S-04A8-2	R0	3.7	.75	4.6	1.0
ACH180-04S-06A9-2	R1	4.6	1.0	6.6	1.5
ACH180-04S-07A8-2	R1	6.6	1.5	7.5	2.0
ACH180-04S-09A8-2	R1	7.5	2.0	9.3	2.0+
ACH180-04S-15A6-2	R2	9.3	2.0+	14.6	4.0
ACH180-04S-17A5-2	R2	14.6	4.0	16.7	5.0
ACH180-04S-25A0-2	R3	16.7	5.0	24.2	7.5
ACH180-04S-033A-2	R3	24.2	7.5	30.8	10.0
ACH180-04S-048A-2	R4	30.0	10.0	46.2	15.0

3-phase, $U_N = 400\text{ V}$ (range 380 to 480 V). The power ratings are valid at nominal voltage 400 V (0.75 to 30HP).

Drive type	Frame size	Ratings		Light-duty use	
		I_{Hd} (A)	P_{HD} (hp)	I_{Ld} (A)	P_{Ld} (hp)
ACH180-04S-01A8-4	R0	1.1	.5	1.6	.75
ACH180-04S-02A6-4	R0	1.6	.75	2.1	1.0
ACH180-04S-03A3-4	R0	2.1	1.0	3.0	1.5
ACH180-04S-04A0-4	R1	3.0	1.5	3.5	2.0
ACH180-04S-05A6-4	R1	3.5	2.0	4.8	3.0
ACH180-04S-07A2-4	R1	4.8	3.0	6.0	3.0
ACH180-04S-09A4-4	R1	6.3	3.0	7.6	5.0
ACH180-04S-12A6-4	R2	7.6	5.0	11.0	7.5
ACH180-04S-17A0-4	R2	11.0	7.5	14.0	10.0
ACH180-04S-25A0-4	R3	14.0	10.0	21.0	15.0
ACH180-04S-033A-4	R3	21.0	15.0	27.0	20.0
ACH180-04S-038A-4	R4	27.0	20.0	34.0	25.0
ACH180-04S-045A-4	R4	34.0	25.0	40.0	30.0
ACH180-04S-050A-4	R4	42.0	30.0	42.0	30.0
ACH180-04S-055A-2*	R4	44.0	15.0	50.2	20.0

x (in type code) = S

S = Standard offering with STO and EMC filter

1-phase 200 to 240 V: Class C2

3-phase 200 to 240 V: Class C3

3-phase 380 to 480 V: Class C3

For further information,

please see the user's HW manual

Heavy-duty use

I_{Hd} Maximum output current with 150% overload, allowed for 1 minute every 10 minutes at 50 °C

P_{HD} Typical motor power in heavy-duty use (150% overload)

Light-duty use

I_{Ld} Continuous current allowing 110% I_{Ld} for 1 minute every 10 minutes at 40 °C.

P_{Ld} Typical motor power in light-duty use.

For derating at higher altitudes, temperatures or switching frequencies, see the user's HW manuals, document codes: 3AXD50000955862.

Dimensions

ACH180 UL open type /IP20

Frame size	Height 1 in (mm)	Height 2 in (mm)	Width in (mm)	Depth in (mm)	Weight lbs (kg)
R0	6.85 (174)	8.23 (209)	2.76 (70)	5.63 (143)	2.03 (0.9)
R1	7.48 (190)	8.66 (220)	2.76 (70)	5.63 (143)	2.73 (1.24)
R2	7.95 (202)	9.06 (230)	4.72 (120)	5.63 (143)	4.23 (1.92)
R3	8.07 (205)	9.49 (241)	6.69 (170)	6.85 (174)	7.28 (3.3)
R4	8.07 (205)	9.45 (240)	10.24 (260)	7.03 (178)	11.69 (5.3)

Height 1: Total height of the drive without grounding plate.

Height 2: Total height of the drive with grounding plate.

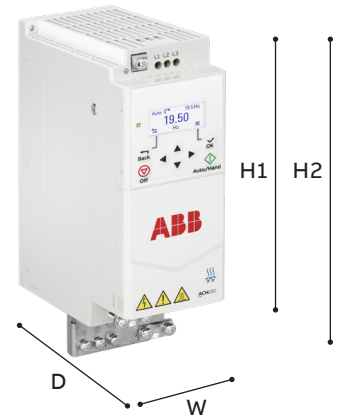

Cooling and fuses

Cooling

ACH180 drives are fitted with cooling air fans. The cooling air must be free of corrosive materials and must not exceed the maximum ambient temperature of 40 °C (up to 60 °C with derate).

Fuses

Standard fuses can be used with the ACH180. For input fuses, see the table below. Manual motor protectors can also be used. See hardware manual for details.

Cooling airflow and recommended input protection fuses							
1-phase $U_N = 230\text{ V}$ (range 200 to 240 V)							
Drive type	Frame size	Heat dissipation (W)	Airflow (m ³ /h)	Max. noise level (dBA)	UL fuses		
					(A)	Fuse type	
ACH180-04S-02A4-1	R0	32	— ^{*)}	— ^{**)}	6	UL class T	
ACH180-04S-03A7-1	R0	44	— ^{*)}	— ^{**)}	10	UL class T	
ACH180-04S-04A8-1	R0	53	— ^{*)}	— ^{**)}	15	UL class T	
ACH180-04S-06A9-1	R1	80	27	51.8	20	UL class T	
ACH180-04S-07A8-1	R1	82	27	51.8	25	UL class T	
ACH180-04S-09A8-1	R1	106	27	51.8	35	UL class T	
ACH180-04S-12A2-1	R2	141	130	62.0	35	UL class T	

Cooling airflow and recommended input protection fuses							
3-phase $U_N = 230\text{ V}$ (range 200 to 240 V)							
Drive type	Frame size	Heat dissipation (W)	Airflow (m ³ /h)	Max. noise level (dBA)	UL fuses		
					(A)	Fuse type	
ACH180-04S-02A4-2	R0	32	— ^{*)}	— ^{**)}	6	UL class T	
ACH180-04S-03A7-2	R0	44	— ^{*)}	— ^{**)}	10	UL class T	
ACH180-04S-04A8-2	R0	53	— ^{*)}	— ^{**)}	10	UL class T	
ACH180-04S-06A9-2	R1	80	27	51.8	15	UL class T	
ACH180-04S-07A8-2	R1	82	27	51.8	20	UL class T	
ACH180-04S-09A8-2	R1	106	27	51.8	20	UL class T	
ACH180-04S-15A6-2	R2	168	130	62.0	30	UL class T	
ACH180-04S-17A5-2	R2	198	130	62.0	35	UL class T	
ACH180-04S-25A0-2	R3	160	128	66.0	40	UL class T	
ACH180-04S-033A-2	R3	407	128	66.0	50	UL class T	
ACH180-04S-048A-2	R4	319	150	69.0	70	UL class T	
ACH180-04S-055A-2	R4	319	150	69.0	70	UL class T	

^{*)} Frame size R0 with free convection cooling. ^{**)} Frame size R0 is noise-free.

Cooling airflow and recommended input protection fuses							
3-phase $U_N = 400\text{ V}$ (range 380 to 480 V)							
Drive type	Frame size	Heat dissipation (W)	Airflow (m ³ /h)	Max. noise level (dBA)	UL fuses		
					(A)	Fuse type	
ACH180-04S-01A8-4	R0	30	— ^{*)}	— ^{**)}	6	UL class T	
ACH180-04S-02A6-4	R0	40	— ^{*)}	— ^{**)}	6	UL class T	
ACH180-04S-03A3-4	R0	51	— ^{*)}	— ^{**)}	10	UL class T	
ACH180-04S-04A0-4	R1	67	36.3	50.9	10	UL class T	
ACH180-04S-05A6-4	R1	97	36.3	50.9	20	UL class T	
ACH180-04S-07A2-4	R1	103	36.3	50.9	20	UL class T	
ACH180-04S-09A4-4	R1	136	36.3	50.9	25	UL class T	
ACH180-04S-12A6-4	R2	157	130.4	62.0	30	UL class T	
ACH180-04S-17A0-4	R2	224	130.4	62.0	35	UL class T	
ACH180-04S-25A0-4	R3	319	128.0	66.0	40	UL class T	
ACH180-04S-033A-4	R3	551	128.0	66.0	60	UL class T	
ACH180-04S-038A-4	R4	537	150.0	69.0	70	UL class T	
ACH180-04S-045A-4	R4	638	150.0	69.0	70	UL class T	
ACH180-04S-050A-4	R4	638	150.0	69.0	70	UL class T	

^{*)} Frame size R0 with free convection cooling. ^{**)} Frame size R0 is noise-free.

Control panel options and mounting kits

The ACH180 drive has an integrated icon-based control panel with a display and control keys. External alphanumeric, multilingual control panels with an optional Bluetooth connection are also available for installation on a cabinet door.



Integrated control panel as standard

The ACH180 comes with the integrated icon-based control panel as standard. You do not need to know any drive parameters, because the control panel helps you to set up the essential settings quickly and get the drive into action. In addition, the ACH180 supports the assistant alphanumeric control panels.



Control panel mounting platform DPMP-02

This mounting platform is for surface mounting. The panel mounting platform does not include the control panel.



Assistant control panel ACH-AP-H

The optional assistant control has a graphical multilingual display. There is no need to know any drive parameters, because the control panel helps you set up the essential settings quickly and get the drive into action without hassle.



Control panel mounting platform DPMP-04

Enables control panel outdoor mounting thanks to IP66 protection class, UV resistance and IK07 impact protection rating.



Bluetooth assistant control panel ACH-AP-W

The optional Bluetooth panel enables connection with the Drivetune mobile app. The app is available for free from Google Play and the Apple App Store. Together with the Drivetune app and the Bluetooth panel, users can commission and monitor the drive remotely, for example.

Control panel options

Description	Control panel
Assistant control panel (Hand-Off-Auto)	ACH-AP-H
Bluetooth assistant control panel (Hand-Off-Auto)	ACH-AP-W
Control panel mounting platform (surface-mounted)	DPMP-02
Control panel mounting platform (outdoor installation)	DPMP-04

Drivetune mobile app for managing drives via an intuitive interface

Drivetune App provides a powerful tool for performing basic drive start-up and troubleshooting tasks. It is possible to connect with drives and access data available in the Internet at the same time. The wireless Bluetooth

connectivity means that users do not need to enter hazardous or difficult-to-reach work areas to access information necessary to help them commission and tune a drive.



- Startup, commission and tune your drive and application with full parameter access
- Optimize performance via drive troubleshooting features
- Create and share backups and support packages
- Keep track of drives installed base

ABB Ability™ Mobile Connect for drives is a module in the Drivetune app. It gives you the access to the technical support for fast problem solving. Mobile Connect makes all the necessary data instantly available to the expert, providing support.

Remote and rapid access to ABB’s drive experts can save you and your team considerable time, money and headaches. Check Mobile Connect availability in your country.

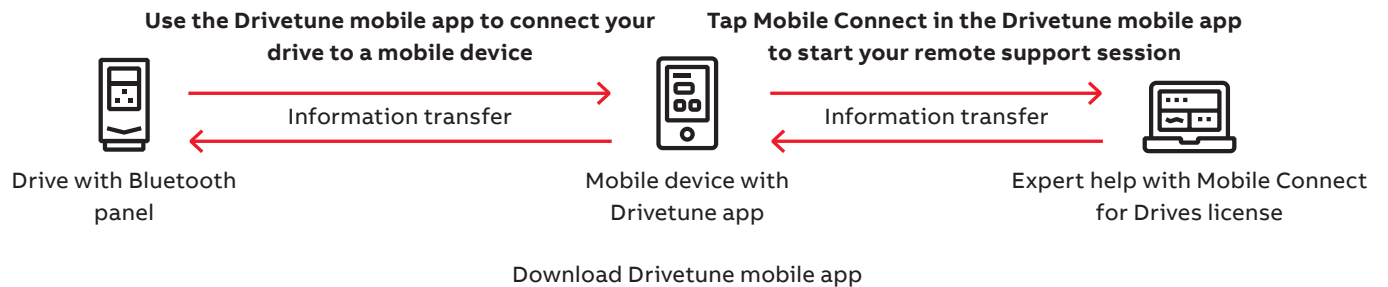

Commissioning, programming, customization and monitoring tools

Your engineering efficiency is boosted with our tools, giving you the optimal solution to perform.

Drive Composer

The Drive Composer PC tool offers fast and harmonized setup, commissioning and monitoring for all-compatible drives. The free version of the tool provides startup and maintenance capabilities and gathers all drive information, such as parameter loggers, faults, backups and lists, into a support diagnostics file. Drive Composer pro provides additional features such as custom parameter windows, graphical control diagrams of the drive's configuration, and improved monitoring and diagnostics.

Drive Composer could be used to set up adaptive programming. Adaptive programming is embedded inside the drive, is especially handy when there is a need to distribute some of the machine's control logic to the drive, it brings energy savings when the drive is adjusted to control the application optimally. Adaptive programming makes it possible to enhance the existing application control program to precisely fit users' application needs.

Drive Composer	Entry level (free)	Pro level
	Basic functionality	Entry-level features
	Multi-language UI	Networked drives
	Parameter setting	Control diagrams
	Backup-restore	Data logger(s)
	Adaptive programming	Graphical safety setup
	Simple monitoring	Advanced monitoring
	Single-point connection	Multiple-point connection
	Connection via USB	Connection via USB/Ethernet
	-	Control diagrams
	-	Datalogger
-	Graphical safety setup	

Link	Description
new.abb.com/drives/software-tools/drive-composer	Link to download free Drive Composer entry
	-

Mini USB connection on the panel

When using the Assistant control panel, the Drive Composer tool is connected to the drive using the mini USB connection on the panel.

Mini USB connection on the panel	
	It connects the Drive Composer tool and the drive.

RJ45 connection at the bottom of ACH180

Through the RJ45 connection at the bottom of the drive, use male RJ-45 connector, cable type Cat 5e or better, the other side connects to the RJ-45 behind the control panel.

RJ45 connection	
	It connects drive and control panel.

Safe configuration for unpowered drives

The CCA-01 cold configuration adapter provides a serial communication interface for unpowered ACH180 R2 to R4 drives to configure drive parameters and download new software from PC. With the adapter, safety isolation of both serial communication and control board power supply is possible. The power supply is taken from a PC USB port.

BCBL-01 cable

Using the BCBL-01 cable, the PC can be connected directly to the RJ-45 panel port on the bottom of the ACH180 drive.

DIN rail mounting kit

For ACH180 frames R1 to R2, it is possible to install the drive to a standard 35 mm DIN rail with an optional kit. ACH180 R3/R4 support DIN rail installation as standard. DIN rail installation passes ISTA road transport simulation tests, it ensures that the ACH180 installed in the electrical cabinet is stable and reliable during transportation.

Cold configurator



Users can download the software and parameters to drives without powering ACH180 R2 to R4 drive.

Description	Type designation
Cold configurator adapter, packed kit	CCA-01

BCBL-01



It connects PC and RJ-45 panel port.

Description	Type designation
PC cable, USB to RJ-45	BCBL-01

DIN rail mounting kit

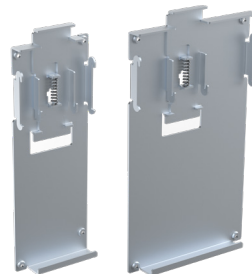

It connects the drive and DIN rail.

Description	Type designation
DIN rail mounting kit for R1 (5 sets per each package)	BDRK-01
DIN rail mounting kit for R2 (5 sets per each package)	BDRK-02

ACH180 All compatible family



All-compatible drives portfolio

The all-compatible drives share the same architecture, software platform, tools, user interfaces and options. Yet, there is an optimal drive from the smallest water pump to the biggest refrigeration compressor, and everything in between.



AC motors

We offer a complete line of HVAC motors designed to perform in the harshest applications while lowering total cost of ownership. We have motors available with integrated internal shaft grounding systems, motors for chiller/cooling towers, condenser and fan applications and more.



Control panels

CP600-eCo, CP600 and CP600-Pro control panels offer a wide range of features and functionalities for maximum operability. ABB control panels are distinguished by their robustness and easy usability, providing all the relevant information from machines at a single touch.



Programmable logic controllers, PLCs

The AC500, AC500-eCo, AC500-S and AC500-XC scalable PLC ranges provide solutions for small, medium and high-end applications. Our AC500 PLC platform offers different performance levels and is the ideal choice for high availability, extreme environments, condition monitoring, or safety solutions.



Our service expertise, your advantage

ABB Motion Services helps customers around the globe by maximizing uptime, extending product life cycle, and enhancing the performance and energy efficiency of electrical motion solutions. We enable innovation and success through digitalization by securely connecting and monitoring our customers' motors and drives, increasing operational uptime, and improving efficiency. We make the difference for our customers and partners every day by keeping their operations running profitably, safely and reliably.

With a service offering tailored to your needs, ABB Motion Services maximizes the uptime and extends the life cycle of your electrical motion solutions, while optimizing their performance and maximizing your energy efficiency gains throughout the entire lifetime of your applications. We help to keep your applications turning profitably, safely and reliably.

Digitalization enables new smart and secured ways to prevent unexpected downtime while optimizing the operation and maintenance of your assets. We securely connect and monitor your motors, drives or your entire powertrain via our easy-to-use cloud service solutions. Connecting your applications also gives you access to our in-depth service domain expertise.

We quickly respond to your service needs. Together with our partners, local field service experts, and service workshop networks, we provide and install original spare parts to help resolve any issues and minimize the impact of unexpected disruptions.

Our tailored to your needs service offerings and digital solutions will enable you to unlock new possibilities. Not only are we your premier supplier of motion equipment, we are your trusted partner and advisor offering support throughout the entire life cycle of your assets. We ensure your operations run profitably, safely and reliably and continue to drive real world results, now and in the future. Our service teams work with you, delivering the expertise needed to keep your world turning while saving energy every day.



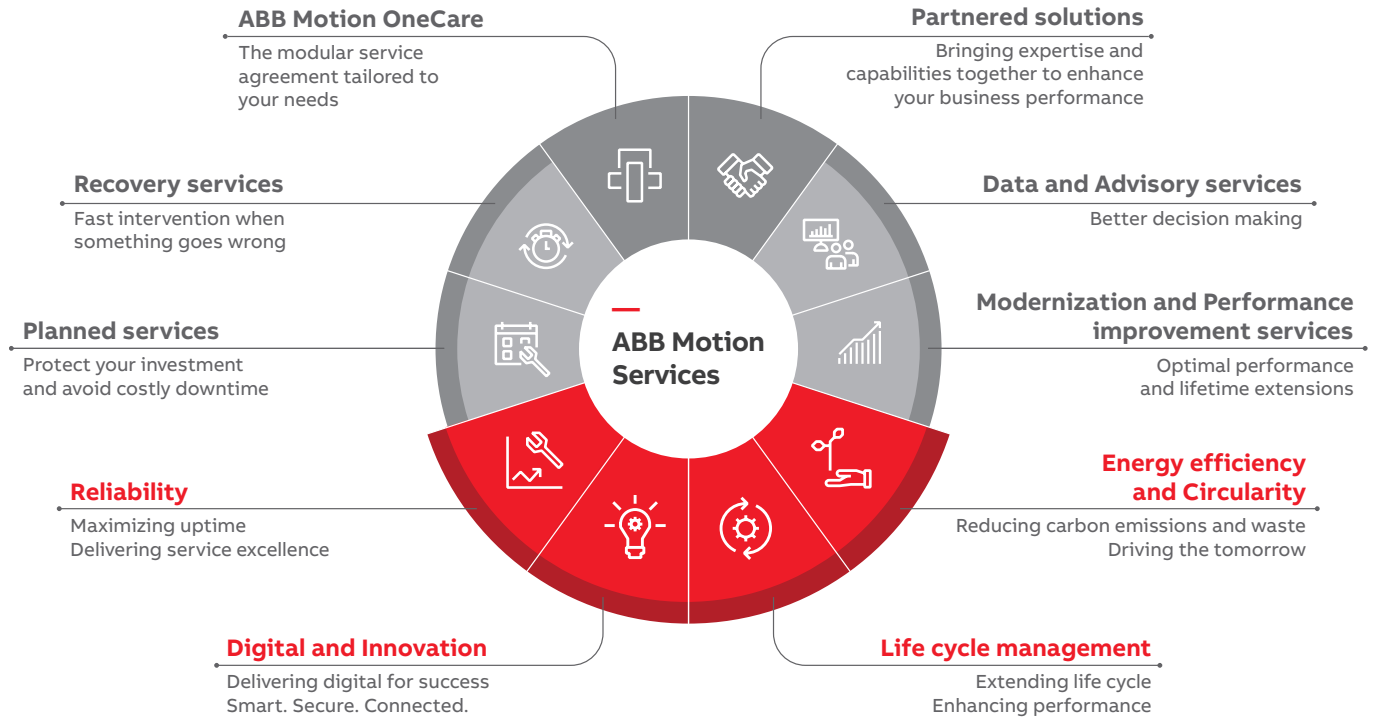

OUR EXPERTISE
YOUR ADVANTAGE

ABB Drives Life Cycle Management

A life time of peak performance

You're in control of every life cycle phase of your drives. At the heart of drive services is a four-phase product life cycle management model. This model defines the services recommended and available throughout drives lifespan.

Now it's easy for you to see the exact service and maintenance available for your drives.

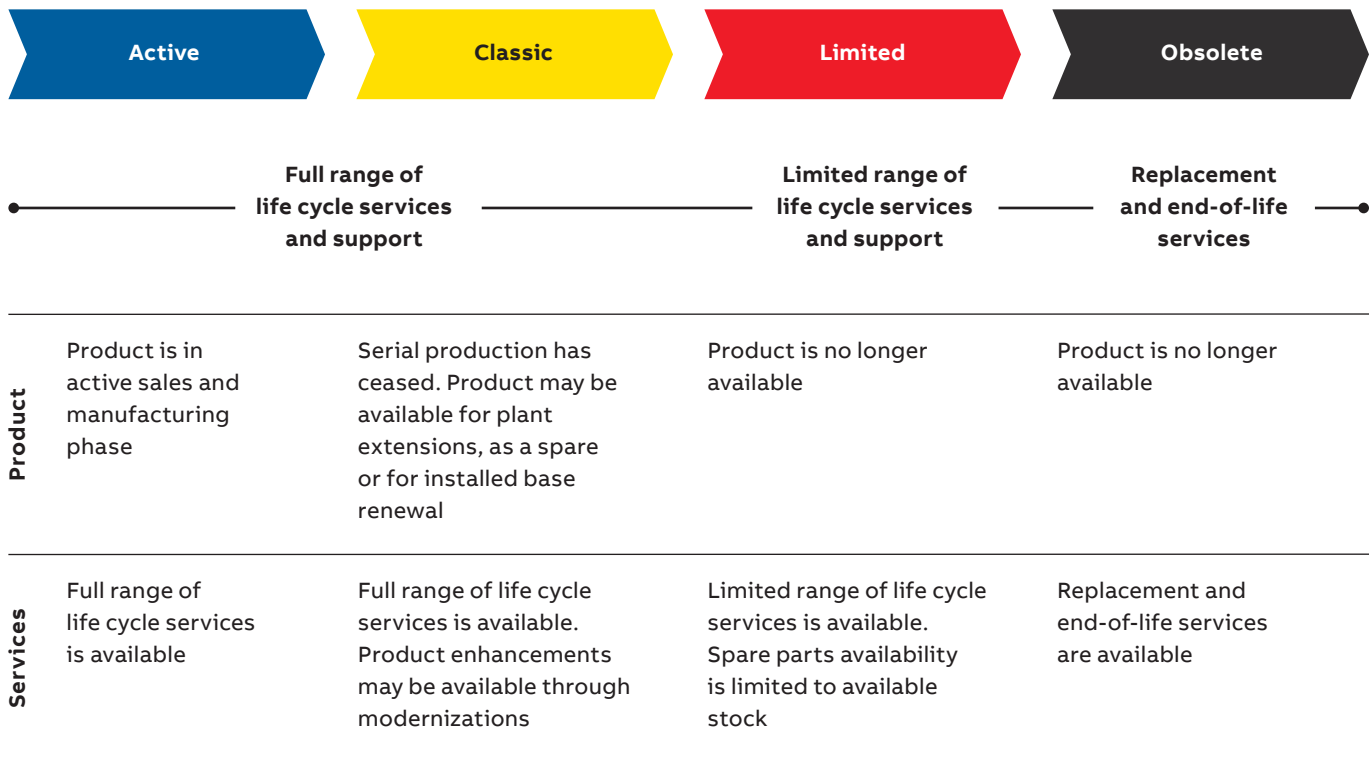

Learn more from
ACH180 website.



Learn more from ABB variable speed drives,
motors and PLCs for HVACR website.

